

2-step thermostats, type CAS 1080

Description



CAS 2-step thermostats are temperature-controlled switches. The position of the contacts depends on the temperature of the sensor and the setting of the thermostat. In this series, special attention has been given to meeting demands for a high level of enclosure, robust and compact construction, and resistance to shock and vibration.

The CAS series covers most outdoor as well as indoor application requirements. CAS thermostats are suitable for use in monitoring and alarm systems in factories, diesel plant, compressors, power stations and on board ship.

CAS with remote sensor

Approvals

CE marked acc. to EN 60947-5-1 and EN 60947-4-1
CCC, China Compulsory Certificate

Ship approvals

American Bureau of Shipping, USA
Bureau Veritas, France
Det Norske Veritas, Norway
Germanischer Lloyd, Germany
Lloyd Register of Shipping, UK
Nippon Kaiji Kyokai, Japan
Registro Italiano Navale, Italy
RMRS, Russian Maritime Register of Shipping

Properties acc. to EN 60947

Wire dimensions		
Solid/ stranded	mm ²	0.2 - 1.5
Flexible, w/out ferrules	mm ²	0.2 - 1.5
Flexible, with ferrules	mm ²	0.2 - 1
Tightening torque	Nm	max. 1
Rated impulse voltage	kV	4
Pollution degree		3
Short circuit protection, fuse	Amp	2
Insulation	V	250
IP index		67

Note: In addition we refer to the certificates, the copies of which can be ordered from Danfoss.

Technical data and ordering

When ordering, please state type and code number

Factory setting		Mechanical differential °C	Max. temperature °C	Insert sensor length mm	Code no.	Type
Step 1	Step 2					
100 °C	115 °C	2.0	220	75	060L500166	CAS 1080
80 °C	80 °C	2.0	220	200	060L502066	CAS 1080

Switch

Microswitch with single pole changeover (2 x SPDT)

Contact load

Alternating current:
220 V, ~0,1 A, AC-14 and AC-15 (inductive load)

Direct current

125 V, 12W DC-13 (inductive load)

Ambient temperature

-25 → +70°C

Vibration resistance

Vibration-stable in the range 2-30 Hz, amplitude 1,1 mm and 30-100 Hz, 4 G.

Enclosure

IP 67 acc. to IEC 529 and DIN 40050. The thermostat housing is enamelled pressure die cast aluminium (GD-AISI 12). The cover is made of plastics and fastened by four screws which are anchored to prevent loss. The enclosure can be sealed with fuse wire.

Cable entry

2 x Pg 13.5 for cable diameters from 5 to 14 mm.

Identification

The type designation and code no. of the unit is stamped in the side of the housing.

Other accessories	Description	Qty./unit	Code no.
Heat conductive compound Tube with 4.5 cm ²	 <p>For CAS thermostats with sensor fitted in a sensor pocket. For filling sensor pocket to improve heat transfer between pocket and sensor. Application range for compound: -20 to 150°C, momentarily up to 220°C</p>	10	041E0114

Installation

Location of unit: CAS thermostats are designed to withstand the shocks that occur, for example, in ships on compressors and in large machine installations.

Resistance to media
Material specifications for sensor pockets.

Sensor pocket brass
The tube is made of Ms 72 to DIN 17660, the threaded portion of So Ms 58 Pb to DIN 17661.

Sensor position
As far as possible the sensor should be positioned so that its longitudinal axis is at right angles to the direction flow. The active part of the sensor is Ø13 mm x 47.5 mm.

The medium
The fastest reaction is obtained from a medium having high specific heat and high thermal conductivity. It is therefore advantageous to use a medium that fulfils these conditions (provided there is a choice). The flow velocity of the medium is also of significance. (The optimum flow velocity for liquids is about 0.3 m/s).
For permissible media pressure see fig. 1.

Electrical connection
CAS thermostats are fitted with a Pg 13.5 screwed cable entry suitable for cables from 5 to 14 mm.
Contact function, see fig. 2.

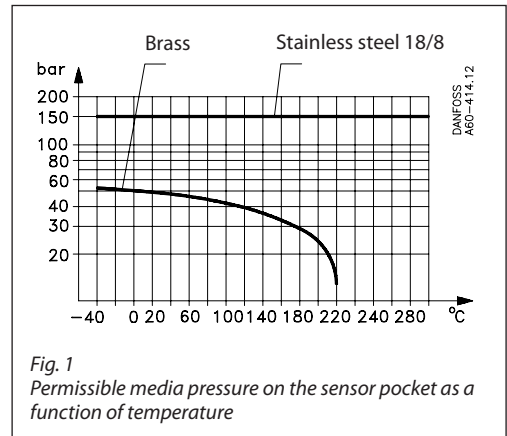
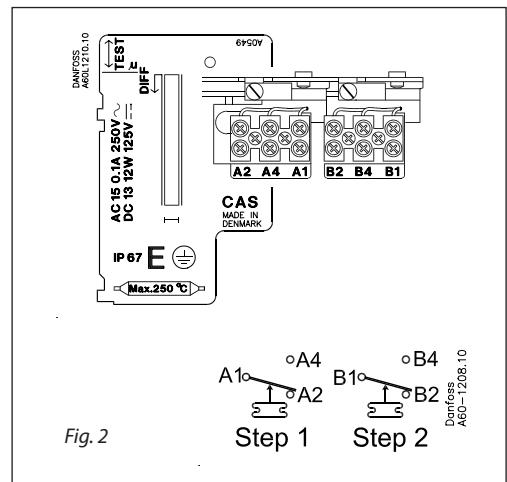

Fig. 1
Permissible media pressure on the sensor pocket as a function of temperature

Setting
CAS 2-step thermostats are only supplied with factory setting. Cannot be changed later.



Function

CAS 1080 thermostats have fixed factory settings. The thermostats with a temperature difference at 15°C between step 1 and step 2 are used for prewarning (step 1) and safety cut out (step 2). The thermostat with factory setting at 80°C of step 1 and step 2 is used for special application,

where double warning - like cranked case fire - is requested.

The contacts automatically reset when the temperature decreases in accordance with the differential.

Differentials

The mechanical differential is the differential determined by the design of the thermostat. The thermal differential (operating differential) is the differential the contact system operates on. The thermal differential is always greater than the mechanical differential and depends on three factors:

- 1) Medium flow velocity
- 2) Temperature change rate of the medium and
- 3) Heat transmission to the sensor

Thermostat function

Contacts 1-4 make while contacts 1-2 break when the temperature rises above the scale setting.

The contacts changeover to their initial position when the temperature falls to the scale setting minus the differential. See fig. 3.

The contacts marked A correspond to step 1. The contacts marked B correspond to step 2.

- I. Alarm for rising temperature given at range setting value.
- II. Alarm for falling temperature given at range setting value minus the differential

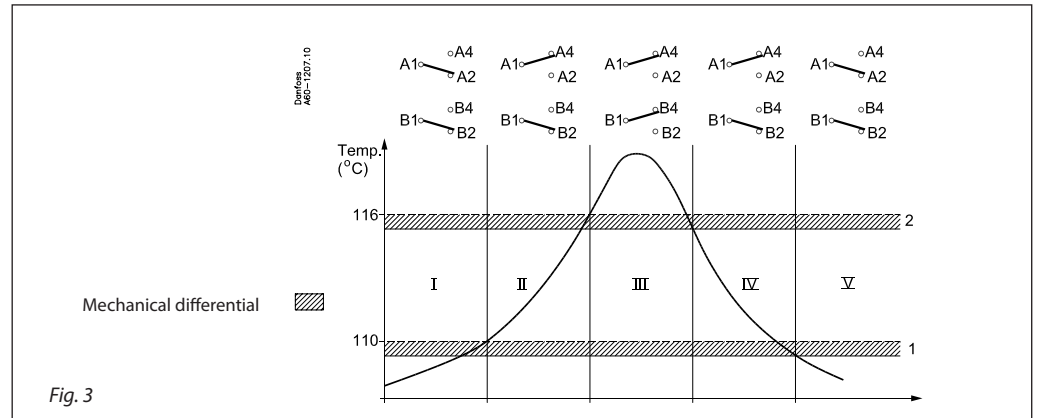

Dimensions and weight

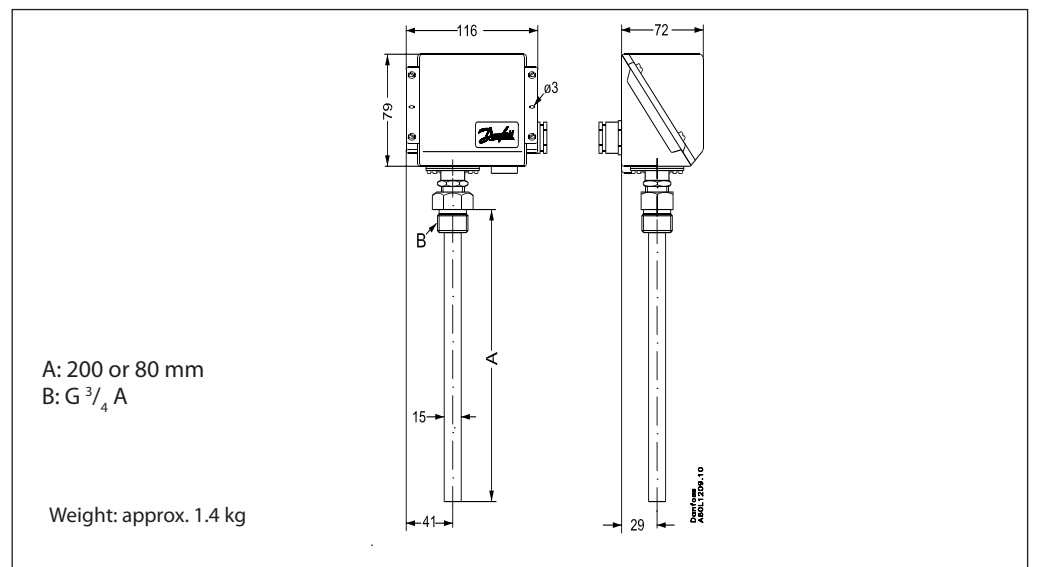

Danfoss can accept no responsibility for possible errors in catalogues, brochures and other printed material. Danfoss reserves the right to alter its products without notice. This also applies to products already on order provided that such alterations can be made without consequential changes being necessary in specifications already agreed. All trademarks in this material are property of the respective companies. Danfoss and the Danfoss logotype are trademarks of Danfoss A/S. All rights reserved.